

## **Advanced monitoring systems for process control**

**Boris Morgenroth & Warner Weiss**

*IPRO Industrieprojekt GmbH, Braunschweig, Germany*  
*Sugars International LLC, Englewood, CO USA*

**Keywords:** process control, process monitoring systems, expert systems, on-line control

### **1 Introduction**

During the last decade's automation systems, process control systems, process and laboratory information systems as well as management information systems (Vogl et al. 2000) have been introduced to the sugar industry and have been developed to a high standard today. These tools offer the advantage of much improved data availability/accessibility and a tremendous decrease in labour costs as well as improving factory operations. However, in other industries (e.g., the petrochemical industry) very advanced expert systems are already state of the art. The "missing link" between the current data & information architecture and the implementation of expert systems is a consistent on-line mass and energy balance of sugar factories.

The aim of the **A**dvanced **M**onitoring **S**ystems (AMS) developed by IPRO Industrieprojekt GmbH & Sugars International LLC is to provide an "on-line" mass, energy and colour balance of a sugar factory and to close the information gap in order to implement expert systems.

### **2 Objectives for the development of the Advanced Monitoring System**

Indicative milestones of process control and automation development in the sugar industry are shown in figure 1. In modern sugar factories, process control systems (PCS), laboratory information systems (LIS) and management information systems (MIS) are state of the art. These systems offer already a high degree of process reliability and enable the management to create technical and economical

evaluations. However, these tools do not offer the advantage of a really transparent process.

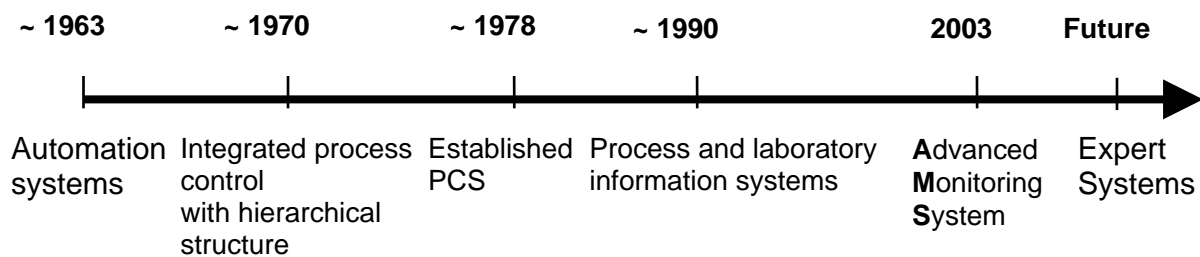

**Figure 1:** Process control and automation development milestones

On the basis of spreadsheet programs (e.g., Microsoft® Excel) individual or global balances can be presented. However, these are generally individual solutions without any standardization and not applicable to another process or unit. The maintenance of these systems necessitates highly qualified personnel and they present many possibilities for errors because of their complexity. Up to now, no real on-line monitoring systems were available that were capable of showing a consistent mass, energy and colour balance for a sugar factory. The aim here is not only to countercheck on-line data measured with various instruments in the process, but also to obtain direct information about energy and auxiliary material flows as well as to integrate the results into economic evaluations.

The task of the PCS is the control and regulation of individual factory sections. In a modern sugar factory, as many as 8,000 to 10,000 instrument tapping points (TAG's) of various kinds are necessary. Up to 3000 values will be recorded. The accuracy of measurements is usually not a determining factor, although this may sound provocative. The aim is to control the process using repeatable measurements and sequences. The laboratory serves the chemical process control. Here too, several hundred measurements are necessary if control of quality parameters is to be included. The knowledge and connection of the PCS and LIS enables a smooth operation of a sugar factory.

A principal demand is that, monitoring systems are easy to handle and based on standard modules that can be easily modified by factory personnel. Data from the PCS as well as the LIS – as far as established – has to be automatically imported into the monitoring system. This raw data can be processed in a calculation module, that is easy to handle and based on visual objects. Excel programs or specifically programmed tools are often too complicated to handle, or there is a high reliance on the manufacturer. While there are many tools available for data management and exchange, there is currently only the program Sugars™ on the market that allows portraying the main sugar process stations with all of their special sub processes in a simple way. The sugar processing scheme for extraction, juice purification, evaporation and crystallization is fully visualized with Sugars using Microsoft® Visio® for the graphical display and these process stations can be easily modified in order to visualize a particular factory. By linking the process data with the Sugars/Visio programs and visualizing the calculation results in a proper way, the technologist achieves a complete overview of the process including mass, energy and colour balances as well as auxiliary materials. Much more information – especially concerning process optimization measures – is available compared to what is offered by processing systems operated today.

The Advanced Monitoring System (AMS) acts as interface between the Process data acquisition system (PDAS) or MIS and shows the following characteristics:

1. **Software tool** processing data from the PCS & LIS
  - Complementary link between **condition and performance monitoring**
  
2. Based on **standard, industry accepted and proven software**
  - Sugars: Process modelling software
  - Visio: Process visualization software
  
3. **On-line mass- energy and colour balance**

4. Only approx. **100 - 150 input variables** are necessary compared to up to 3000 values recorded by the processing system and in the laboratory

Especially the display of the equipment performance is an important tool to optimize the maintenance. The main targets of the AMS and further related aspects can be summarized as follows:

### **AMS Targets**

1. Consistent mass- and energy balance of the process -> **transparent factory**
2. **Equipment performance** can be shown directly
3. Based on processing modules – **avoids mathematical (connection)-errors**
4. System is fully open and programmable – **limited manufacturer reliance**
5. **Easy handling & training** for “non-graduates” e.g., control terminal staff
6. Basis for **expert systems** and equipment performance related **maintenance tools**
7. The Sugars model also can be used for “**What if simulations**” that are a basis for process control decisions and investments
8. **Quick and easy adaptation** of the balanced model in case of connection changes in the process

### **Further aspects**

- Comparison of set points and actual data of AMS and the operation and laboratory management system
  - Detection of errors and their source
- Analysis of performance for individual components in the factory

- Statement of forthcoming cleaning of heat exchangers and evaporators, for example
- Crystal content and supersaturation will be calculated and can reveal problems with the formation of fine grain
- For quality aspects; e.g., the preparation of a colour balance for statements on the effect of different process concepts is possible within a very short time
- Reduction of control points in the process lead to savings in investment-, maintenance- and personnel cost
- Reduction of chemical analyses in the laboratory
- Assistance with investment decisions due to fast adaptation of performance data of single equipment pieces and evaluation of effects on the process
- Recording of on-line data and interpretation/analysis at any time

### **3 Sugars and Visio as basis of the AMS development**

A prerequisite for the development of the AMS system was to use highly developed software tools as presented by the Sugars programme, capable to display the core sugar process. The upgrade from the DOS based Sugars to the Microsoft Windows® and Visio platforms in the year 1999 combines the strength and reliance of the Sugars software with the graphical display provided by Visio. Some remarkable improvements have been added to the programme since the Sugars/ Visio software version has been released. Some of these enhancements are summarized below:

- Flow stream data can now be displayed on the Visio drawing
- A turbine generator station and other improved modules (e.g., compressor, pump, pressure reducer, thermo compressor, turbine) with a new isentropic efficiency calculation for the new turbine generator station are implemented
- Condensate temperature drops in evaporators, pans and heaters can now be specified and evaporators and pans can have their vapour pressure set in a condenser station
- Vapour of evaporators, pans and flash tanks is superheated by the amount of the boiling point elevation

- Improved steam algorithms for higher accuracy
- Much improved database synchronization with drawing objects

The following figures 2 - 4 give a rough overview about the design of the programme. As mentioned, flow stream data can be displayed with the current programme version and it will be possible to transfer data from flow streams and stations to separate spreadsheets with the AMS in order to arrange the results in a suitable way.

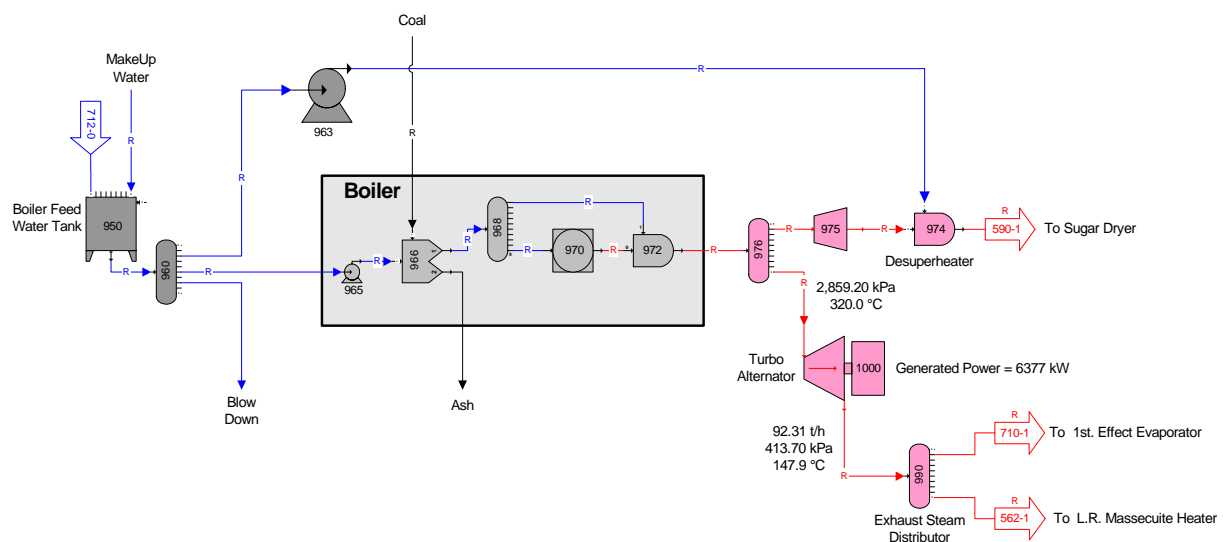

**Figure 2:** Boiler and turbo generator station

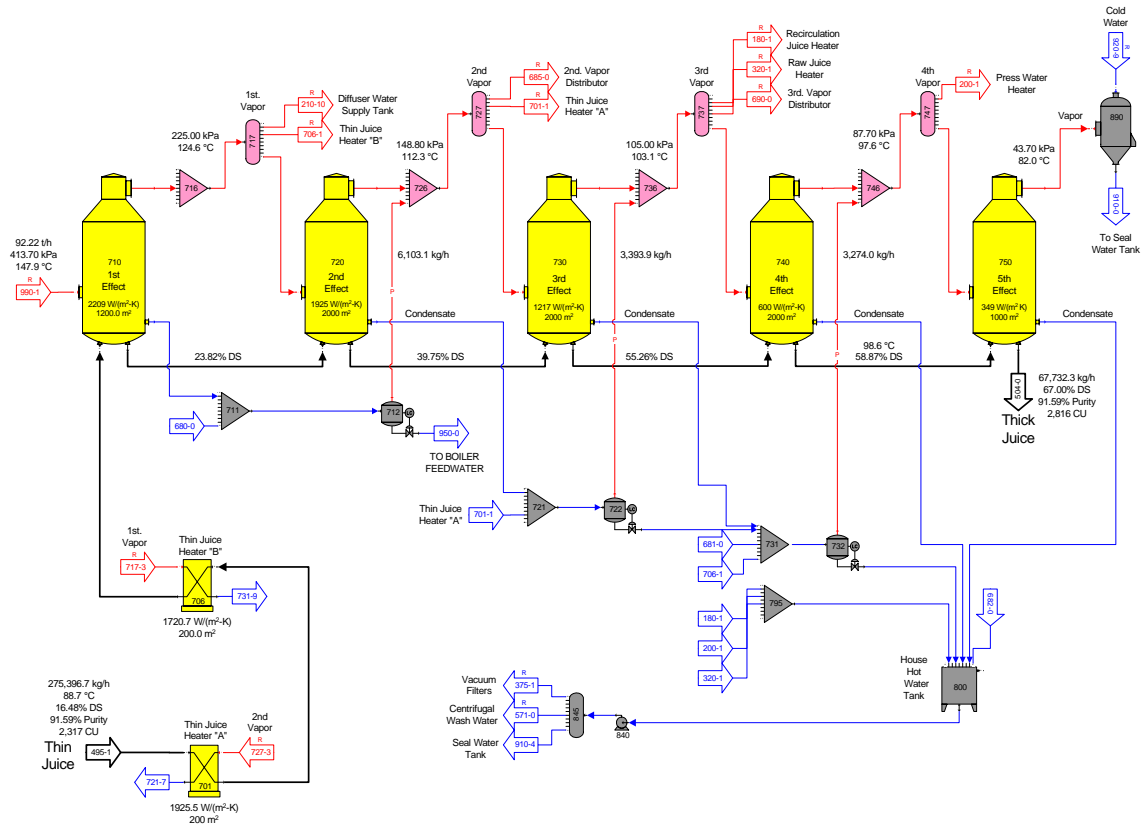

Figure 3: Evaporation station

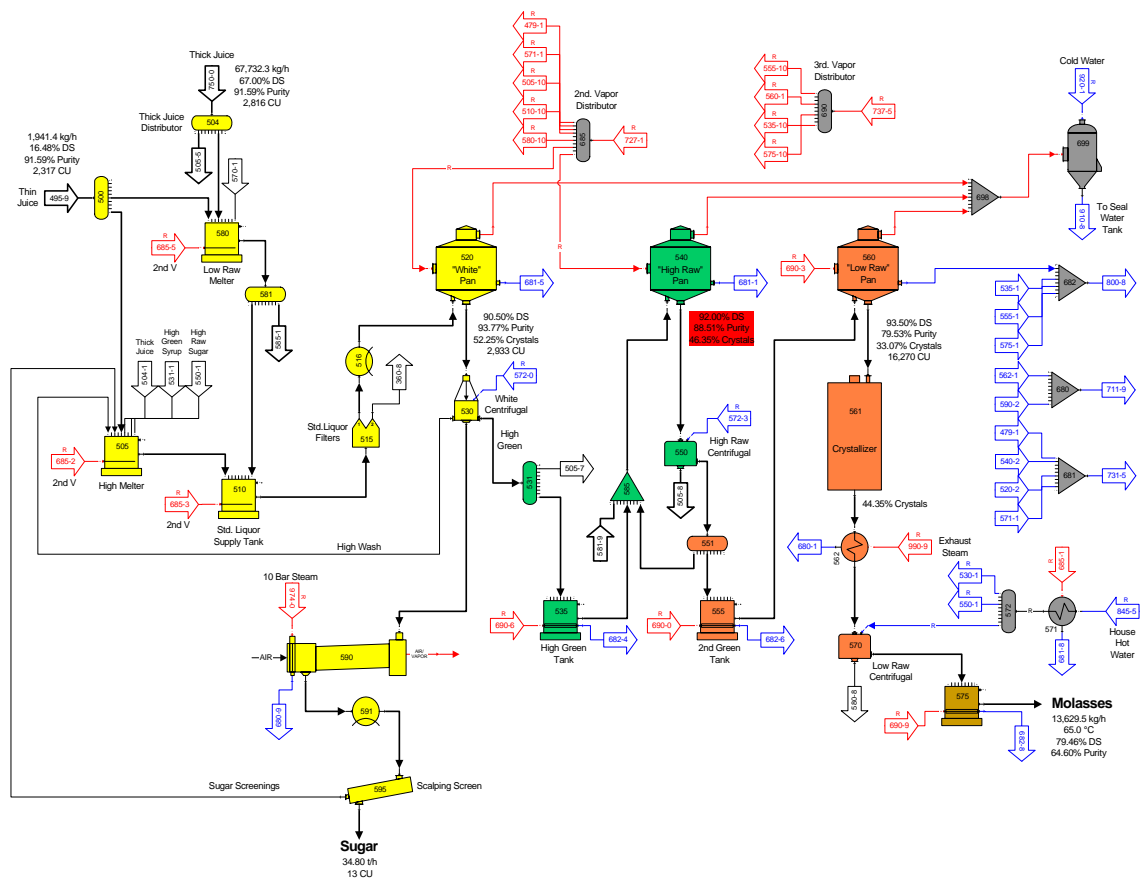
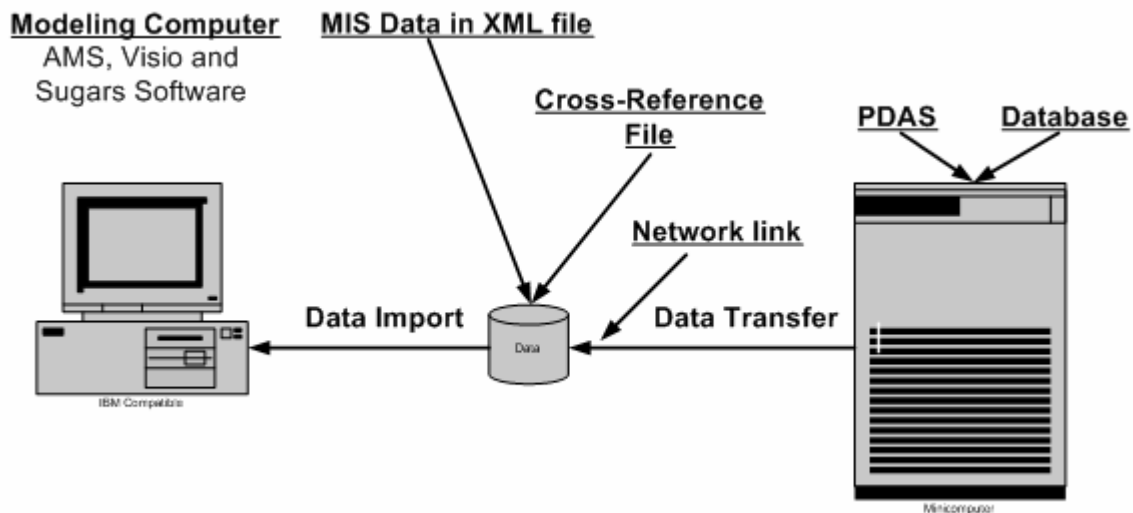

Figure 4: Crystallization station

#### 4 Functional description of the AMS

Features of the AMS include on-demand import, using eXtensible Markup Language (XML), of data into the Sugars model of a factory from the factory's database. XML is the latest web based computer language, and it is well on its way to becoming a standard for data exchange. The data collected by the process data acquisition system (PDAS); e.g., from the PCS and LIS or other databases, will be transferred via the network to a cross reference file that connects the process and the Sugars/ Visio Tag's. The Sugars/ Visio programs are located on a separate machine. Figures 5 & 6 give an overview about the principal integration of the AMS into the factory data network and the AMS operation sequence.

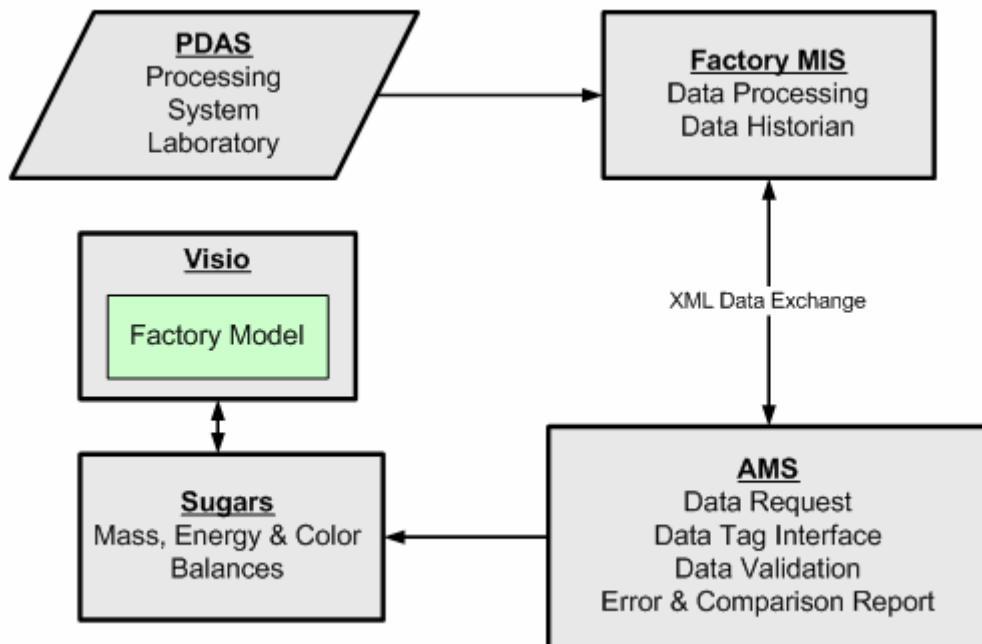

**Figure 5:** Principal arrangement of the AMS and the factory information system

The AMS software will import the XML data file and convert it to station and flow stream values and enter the imported values into the model. During the import the AMS software will check the data for errors. Any errors that are found will be displayed on a comparison and error report that can be requested from the AMS screen that opens after the AMS button is depressed on the Sugars toolbar. Errors to be detected will be data items being imported that are not identified in the model of the factory, out of range values and centrifugal data that is not consistent for doing centrifugal performance calculations. The range of variation allowed without causing

an error for each data item will be set by a percentage value in the AMS that will compare the original value with the imported value to see that the imported value is not more than a specified percentage either above, or below the original value. For example, if the original value in the model is 100.0 and the percentage variation value is 20%, then the imported data value can be as high as 120, or as low as 80 without causing a data import error. The percentage value will be the same for all data and set by an entry from the AMS settings screen. Original data values in the model that are zero will not accept imported data unless an option is selected to import data to 0.0 data in the model because otherwise they would be out of range. MIS systems often already allow a data cross check that ensures, that only a certain range of a value is accepted. Another aspect is to use “moving averages” that can also take into account the residence time in the process.

A comparison report of the imported data and the original data in the model along with any errors that were found during the import will be obtained from a button on the AMS screen. The report shows the original value, the imported value, the difference and any errors.



**Figure 6:** Principal AMS operation sequence

## 5 Presentation of results

Besides the display of the process arrangement and the flow stream and stations data on the drawing, the AMS offers also the possibility to extract data and to rearrange the results in separate spreadsheets or simplified drawings. One of the aims should be a reduction of the “data flood” in order to concentrate on essentials and present these in an efficient and clearly arranged manner. Whereas, a conventional operation- and laboratory data system records up to 3000 data sets, the AMS only needs 100 - 150 measurements. Figure 7 gives an overview about the necessary data (pressures, temperatures and brix) for the balance of the evaporation plant. Of course the evaporation plant is linked to other process stations that determine the amount of vapours transformed within the evaporation plant thus it is not necessary to determine or to measure the brix after every effect.

Effect		1	2	3	4	5
Steam	$p_{St}$ kPa	413.7	225.0	148.8	105.0	87.7
	$t_{St}$ °C	147.9	124.6	112.3	103.1	97.6
	$m_{St}$ t/h	92.22	75.00	31.36	4.59	7.92
Vapor	$p_{Va}$ kPa	225.0	148.8	105.0	87.7	43.7
	$t_{Va}$ °C	124.6	112.4	103.3	98.6	82.0
	$m_{Va}$ t/h	84.9	76.3	32.0	5.0	9.4
Juice, in	$W_{DS}$ %	16.48	23.82	39.75	55.26	58.87
	$t_J$ °C	118.0	124.6	112.4	103.3	98.6
	$m_J$ t/h	275.40	190.49	114.16	82.12	77.09
Juice, out	$W_{DS}$ %	23.82	39.75	55.26	58.87	67.00
	$t_J$ °C	124.6	112.4	103.3	98.6	82.0
	Delta $t_{eff}$ K	20.2	11.6	7.8	2.4	14.0
	k-value $W/(m^2K)$	2209	1925	1217	600	349

**Figure 7:** Example for the display of results within the Visio document

## **6 Data reconciliation**

A comparison of set points and actual values enables an intense analysis of the process performance. The process will become totally transparent with the AMS regarding chemical and physical process parameters as well as mass and energy flows. Anyhow, the AMS results are based on a relative small amount of process data and it is important, that this process data is highly reliable. The AMS does not include any specific data reconciliation procedures yet. Data reconciliation is a task of the technologist and expert systems that can be linked to the AMS in later development steps, where data also can be exported to the MIS.

## **7 Summary and perspectives**

The AMS works in concert with the current factory's process data acquisition system (PDAS) and management information system (MIS) to create a complete overview of the process in graphical form with factory results displayed as needed. A consistent mass, energy and colour balance is created.

The AMS development opens also the prospect for the implementation of expert systems that offer further advanced control possibilities.

In the long term, a reduction of process automation and control equipment as well as a decrease of related maintenance costs shall be achieved.

## **8 Literature**

Vogl, W., Koenig, H., Woehrle, K., Zahrer, R., 2000:  
Automatic integration of process and laboratory data into a Management Information System at the Südzucker factory in Offenau,  
Int. Sugar J. 102

### **Address of authors**

Boris Morgenroth, IPRO Industrieprojekt GmbH, Celler Str. 67, 38114 Braunschweig, Germany, Email: [Morgenroth@ipro-bs.de](mailto:Morgenroth@ipro-bs.de)

Warner Weiss, Sugars International LLC, 30 Glenmoor Drive. Englewood. CO, 80113-7115, USA, Email: [WWeiss@SugarsOnline.com](mailto:WWeiss@SugarsOnline.com)

### **Acknowledgements**

Sugars™ is a trademark of Sugars International LLC

Microsoft® is a registered trademark of Microsoft Corporation

Windows® is a registered trademark of Microsoft Corporation

Visio® is a registered trademark of Microsoft Corporation