

Affination and Purification

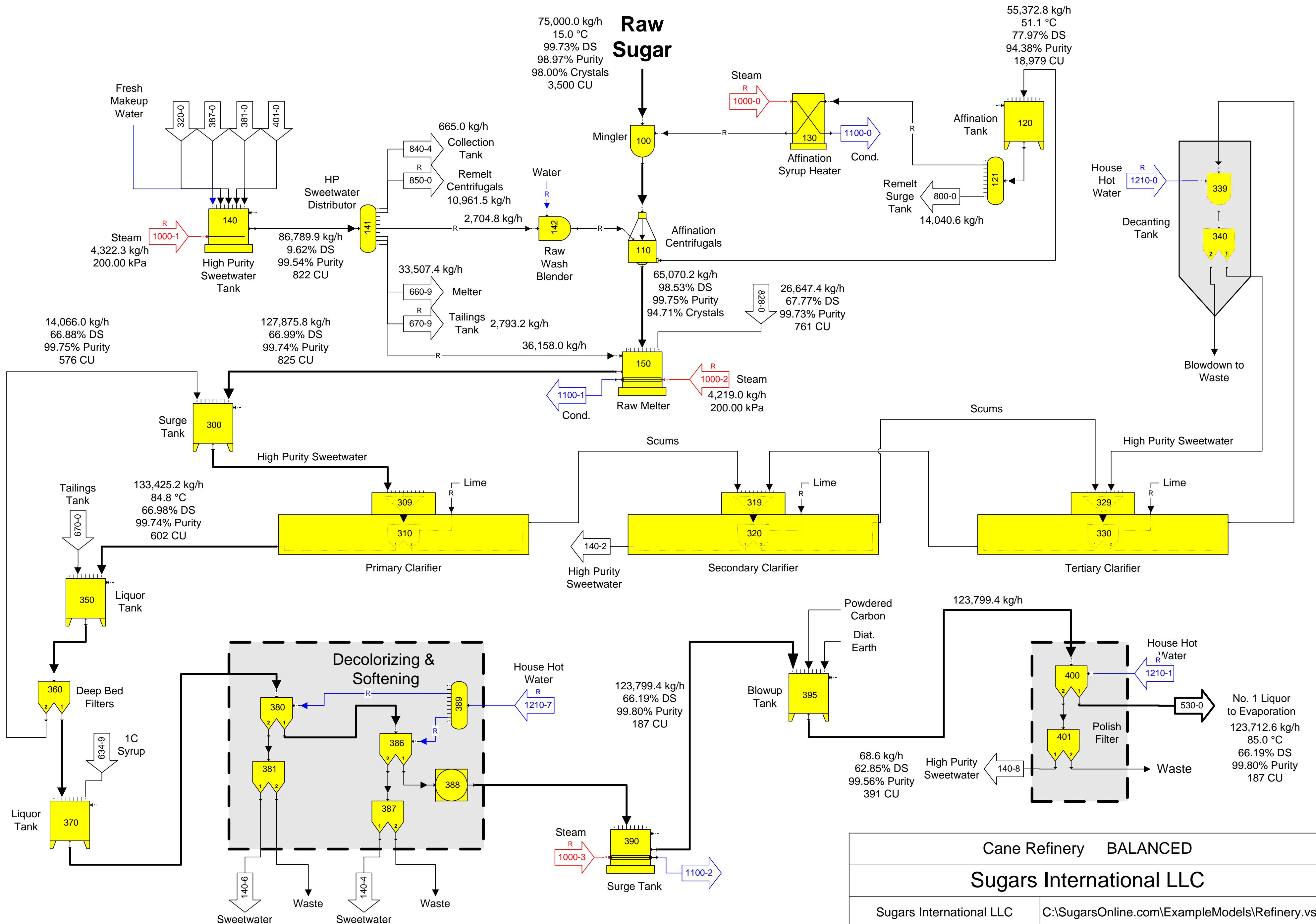

Cane Refinery BALANCED	
Sugars International LLC	
Sugars International LLC	C:\SugarsOnline.com\ExampleModels\Refinery.vsd
6/11/2003 2:11:27 PM	1

Evaporation

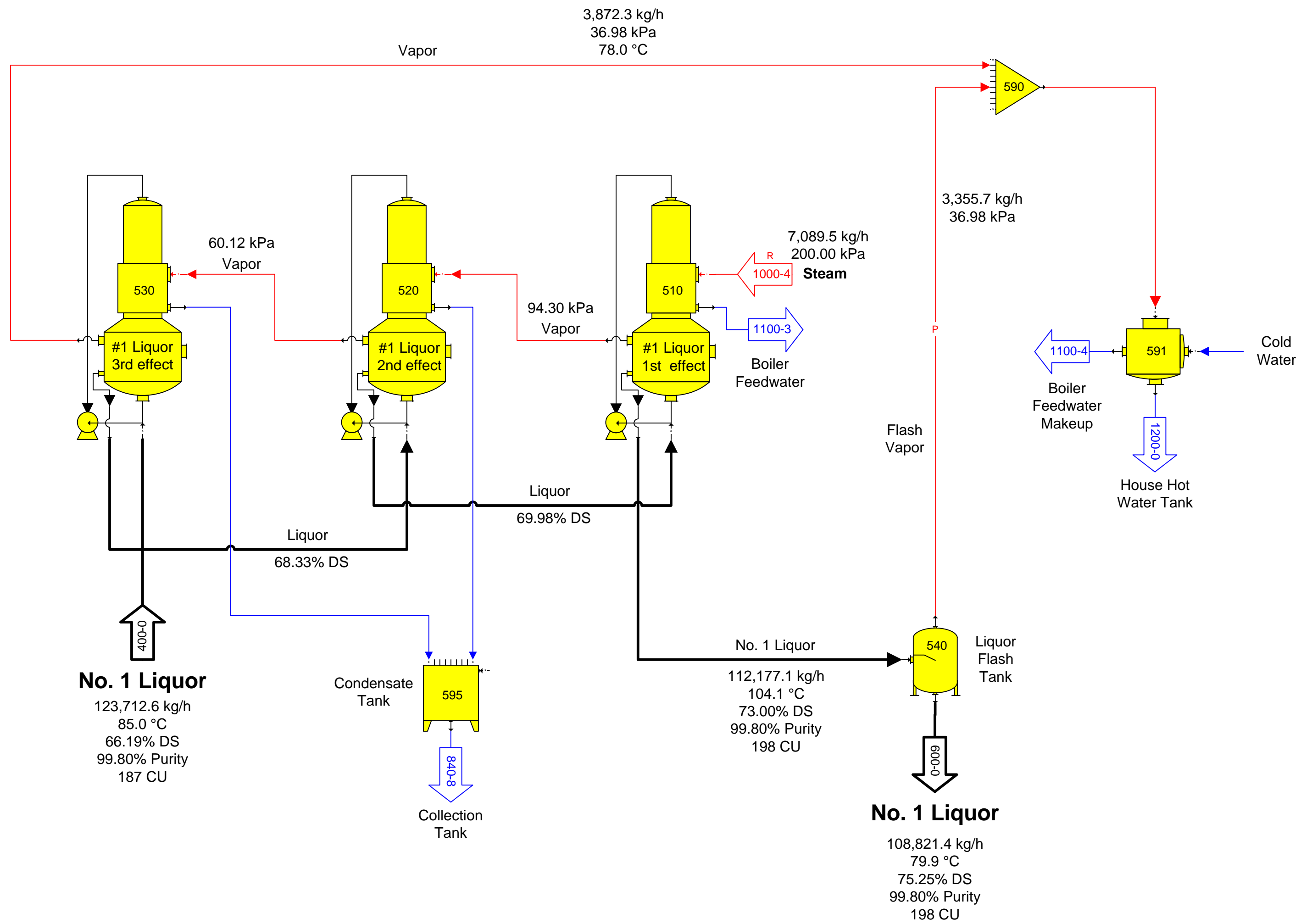

Cane Refinery BALANCED	
Sugars International LLC	
Sugars International LLC	C:\SugarsOnline.com\ExampleModels\Refinery.vsd
6/11/2003 2:11:27 PM	2

Crystallization

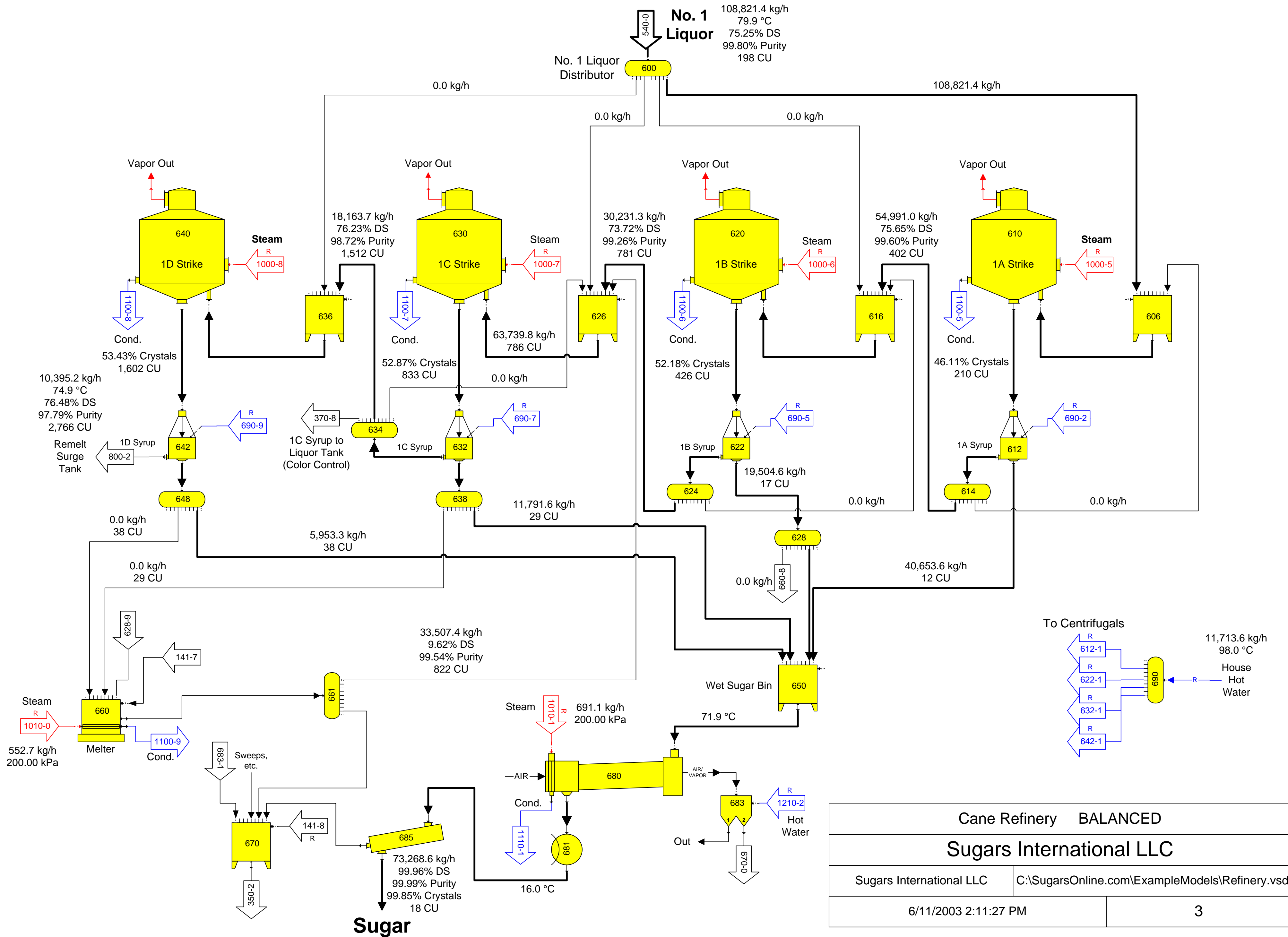

Cane Refinery BALANCED	
Sugars International LLC	
Sugars International LLC	C:\SugarsOnline.com\ExampleModels\Refinery.vsd
6/11/2003 2:11:27 PM	3

Remelt

Sweetwater Evaporators

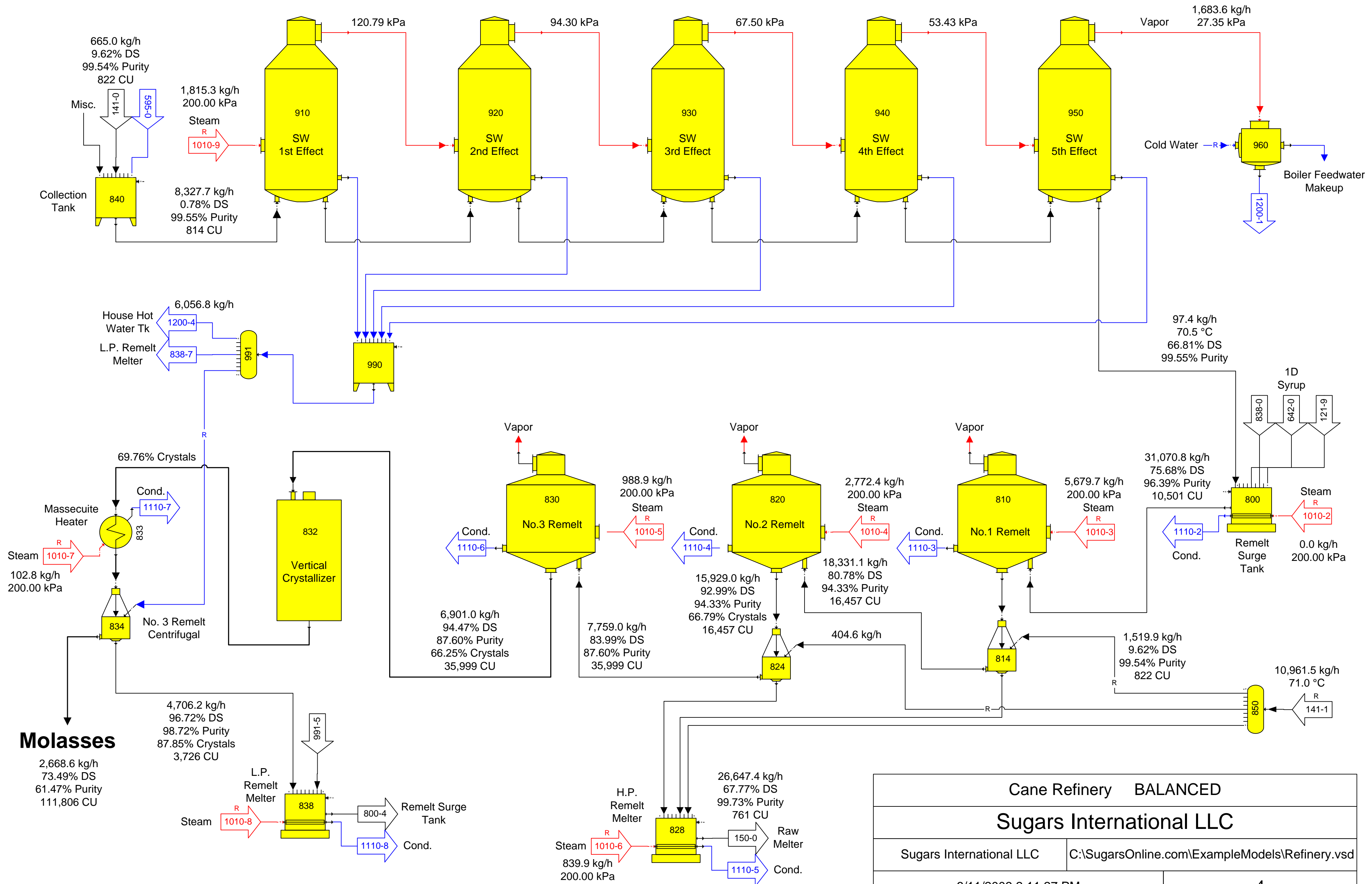

Cane Refinery BALANCED	
Sugars International LLC	
Sugars International LLC	C:\SugarsOnline.com\ExampleModels\Refinery.vsd
6/11/2003 2:11:27 PM	4

Steam and Water Distribution

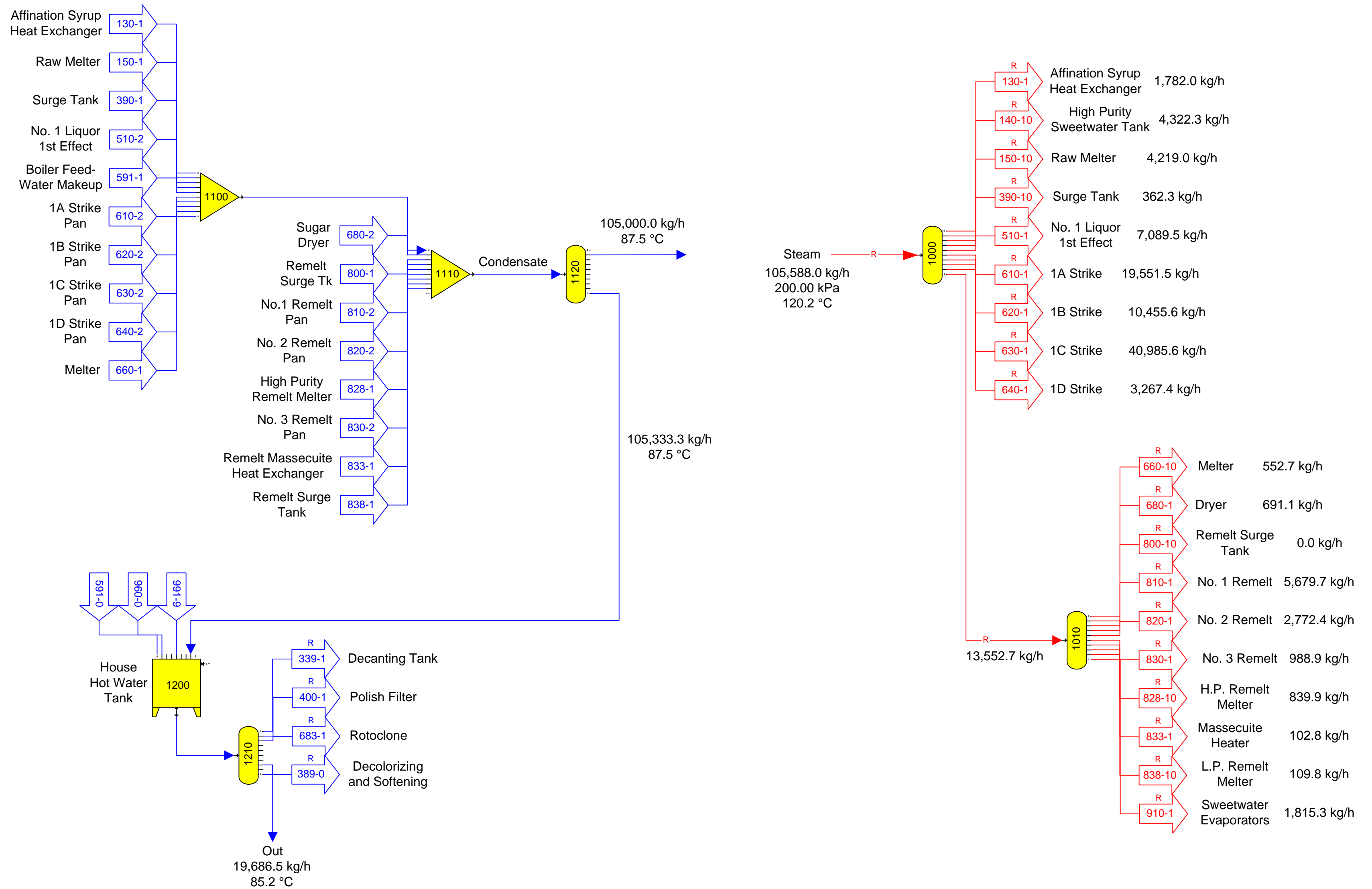

Cane Refinery BALANCED	
Sugars International LLC	
Sugars International LLC	C:\SugarsOnline.com\ExampleModels\Refinery.vsd
6/11/2003 2:11:27 PM	5